

## Installation Instructions

# Horizontal Duct Conversion Kit

## Precedent Packaged Rooftop Units

### 12.5 to 25 Tons

Model Number: FIAHZDC001\*      Used With: T/Y/S\*180-300, W/D/GS\*150-300, T/Y/H\*150-300, T/Y/Z\*150-300

#### SAFETY WARNING

Only qualified personnel should install and service the equipment. The installation, starting up, and servicing of heating, ventilating, and air-conditioning equipment can be hazardous and requires specific knowledge and training. Improperly installed, adjusted or altered equipment by an unqualified person could result in death or serious injury. When working on the equipment, observe all precautions in the literature and on the tags, stickers, and labels that are attached to the equipment.

August 2022

ACC-SVN263A-EN

©2022

1

## Warnings, Cautions, and Notices

Read this manual thoroughly before operating or servicing this unit. Safety advisories appear throughout this manual as required. Your personal safety and the proper operation of this machine depend upon the strict observance of these precautions.

The three types of advisories are defined as follows:

#### WARNING

Indicates a potentially hazardous situation which, if not avoided, could result in death or serious injury.

#### CAUTION

Indicates a potentially hazardous situation which, if not avoided, could result in minor or moderate injury. It could also be used to alert against unsafe practices.

#### NOTICE

Indicates a situation that could result in equipment or property-damage only accidents.

### Important Environmental Concerns

Scientific research has shown that certain man-made chemicals can affect the earth's naturally occurring stratospheric ozone layer when released to the atmosphere. In particular, several of the identified chemicals that may affect the ozone layer are refrigerants that contain Chlorine, Fluorine and Carbon (CFCs) and those containing Hydrogen, Chlorine, Fluorine and Carbon (HCFCs). Not all refrigerants containing these compounds have the same potential impact to the environment. Trane advocates the responsible handling of all refrigerants-including industry replacements for CFCs such as HCFCs and HFCs.

### Important Responsible Refrigerant Practices

Trane believes that responsible refrigerant practices are important to the environment, our customers, and the air conditioning industry. All technicians who handle refrigerants must be certified according to local rules. For the USA, the Federal Clean Air Act (Section 608) sets forth the requirements for handling, reclaiming, recovering and recycling of certain refrigerants and the equipment that is used in these service procedures. In addition, some states or municipalities may have additional requirements that must also be adhered to for responsible management of refrigerants. Know the applicable laws and follow them.

2

#### WARNING

##### Proper Field Wiring and Grounding Required!

Failure to follow code could result in death or serious injury. All field wiring MUST be performed by qualified personnel. Improperly installed and grounded field wiring poses FIRE and ELECTROCUTION hazards. To avoid these hazards, you MUST follow requirements for field wiring installation and grounding as described in NEC and your local/state/national electrical codes.

#### WARNING

##### Personal Protective Equipment (PPE) Required!

Failure to wear proper PPE for the job being undertaken could result in death or serious injury. Technicians, in order to protect themselves from potential electrical, mechanical, and chemical hazards, MUST follow precautions in this manual and on the tags, stickers, and labels, as well as the instructions below:

- Before installing/servicing this unit, technicians MUST put on all PPE required for the work being undertaken (Examples; cut resistant gloves/sleeves, butyl gloves, safety glasses, hard hat/bump cap, fall protection, electrical PPE and arc flash clothing). ALWAYS refer to appropriate Safety Data Sheets (SDS) and OSHA guidelines for proper PPE.
- When working with or around hazardous chemicals, ALWAYS refer to the appropriate SDS and OSHA/GHS (Global Harmonized System of Classification and Labeling of Chemicals) guidelines for information on allowable personal exposure levels, proper respiratory protection and handling instructions.
- If there is a risk of energized electrical contact, arc, or flash, technicians MUST put on all PPE in accordance with OSHA, NFPA 70E, or other country-specific requirements for arc flash protection, PRIOR to servicing the unit. NEVER PERFORM ANY SWITCHING, DISCONNECTING, OR VOLTAGE TESTING WITHOUT PROPER ELECTRICAL PPE AND ARC FLASH CLOTHING. ENSURE ELECTRICAL METERS AND EQUIPMENT ARE PROPERLY RATED FOR INTENDED VOLTAGE.

3

#### WARNING

##### Follow EHS Policies!

Failure to follow instructions below could result in death or serious injury.

- All Trane personnel must follow the company's Environmental, Health and Safety (EHS) policies when performing work such as hot work, electrical, fall protection, lockout/tagout, refrigerant handling, etc. Where local regulations are more stringent than these policies, those regulations supersede these policies.
- Non-Trane personnel should always follow local regulations.

### Copyright

This document and the information in it are the property of Trane, and may not be used or reproduced in whole or in part without written permission. Trane reserves the right to revise this publication at any time, and to make changes to its content without obligation to notify any person of such revision or change.

### Trademarks

All trademarks referenced in this document are the trademarks of their respective owners.

### Inspection

1. Unpack all components of the kit.
2. Check carefully for shipping damage. If any damage is found, report it immediately, and file a claim against the transportation company.
3. Visually inspect the components for shipping damage as soon as possible after delivery, before it is stored. Concealed damage must be reported within 15 days.
4. If concealed damage is discovered, stop unpacking the shipment.
5. Do not remove damaged material from the receiving location. Take photos of the damage, if possible. The owner must provide reasonable evidence that the damage did not occur after delivery.
6. Notify the carrier's terminal of damage immediately by phone and by mail. Request an immediate joint inspection of the damage by the carrier and the consignee.

4

**Note:** Do not attempt to repair any damaged parts until the parts are inspected by the carrier's representative.

## General

There are two sheet metal assemblies that can be used in the unit without any additional preparation work:

- Return duct cover – includes fiber glass insulation
- Supply duct cover – includes insulation, gasket, bracket attached to the panel. [Figure 1](#) shows both assemblies.

**Figure 1. Sheet metal assemblies**

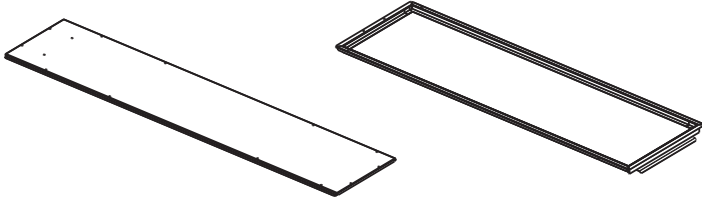

## Installation

### ⚠ WARNING

#### Hazardous Voltage w/Capacitors!

Failure to disconnect power and discharge capacitors before servicing could result in death or serious injury.

Disconnect all electric power, including remote disconnects and discharge all motor start/run capacitors before servicing. Follow proper lockout/ tagout procedures to ensure the power cannot be inadvertently energized. Verify with a CAT III or IV voltmeter rated per NFPA 70E that all capacitors have discharged.

5

1. Remove the return and supply duct cover panels from the unit. See [Figure 2](#). Discard the panels.

**Figure 2. Remove return and supply duct cover panels**

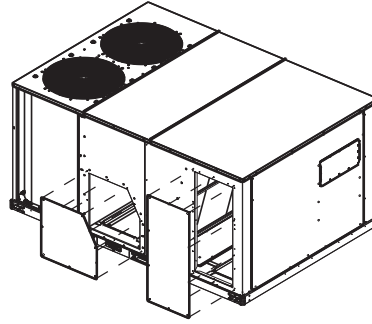

2. Install the return duct cover panel to cover the return opening in the base. See [Figure 3](#). Open the filter access panel to access and secure screws on other side of unit. Pay close attention to screw spacing in order to properly align the panel.

**Figure 3. Install return duct cover panel**

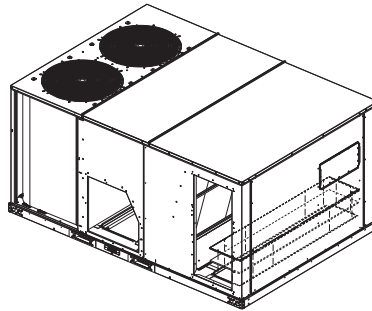

6

3. The supply duct cover panel is ready to be installed. Slide the bracket panel end of the cover panel into the unit first. See [Figure 4](#).

**Important:** Carefully slide the cover panel over the duct opening. Avoid peeling the gasket away from the panel.

**Figure 4. Install supply duct cover panel**

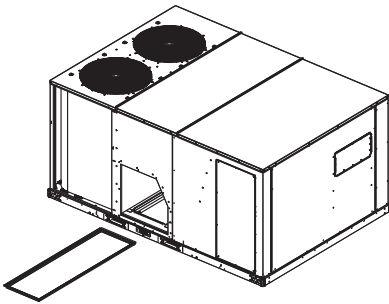

4. Slide supply duct cover panel until the duct cover bracket latches to the base pan. See [Figure 5](#).
5. The holes on the cover panel should line up with the holes on the base pan. Secure the cover panel to the base pan with the screws provided.

7

**Figure 5. Push supply duct cover until it latches to far side duct opening as shown**

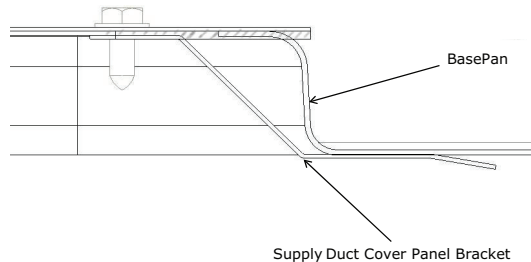

Trane and American Standard create comfortable, energy efficient indoor environments for commercial and residential applications. For more information, please visit [trane.com](http://trane.com) or [americanstandardair.com](http://americanstandardair.com).

Trane and American Standard have a policy of continuous product and product data improvement and reserve the right to change design and specifications without notice. We are committed to using environmentally conscious print practices.